

Relação do aço

ACO	N	DIAM (mm)	QUANT	C.UNIT (cm)	C.TOTAL (cm)
CA60	1	5.0	93	68	6324
CA50	2	5.0	96	54	3024
	3	8.0	36	72	2592
	4	8.0	60	92	5520
	5	8.0	68	122	8052
	6	8.0	28	102	2856
	7	8.0	12	82	984
	8	10.0	36	152	5472
	9	12.5	8	160	1280
	10	12.5	12	209	2508

Resumo do aço

ACO	DIAM (mm)	C.TOTAL (m)	PESO + 10 % (kg)
CA50	8.0	200.1	86.8
	10.0	54.8	37.1
	12.5	37.9	40.1
CA60	5.0	93.5	15.8
PESO TOTAL (kg)			
CA50		164.1	
CA60		15.8	

Volume de concreto (C-25) = 0.37 m³
Volume de concreto (C-30) = 2.5 m³
Área de forma = 17.78 m²

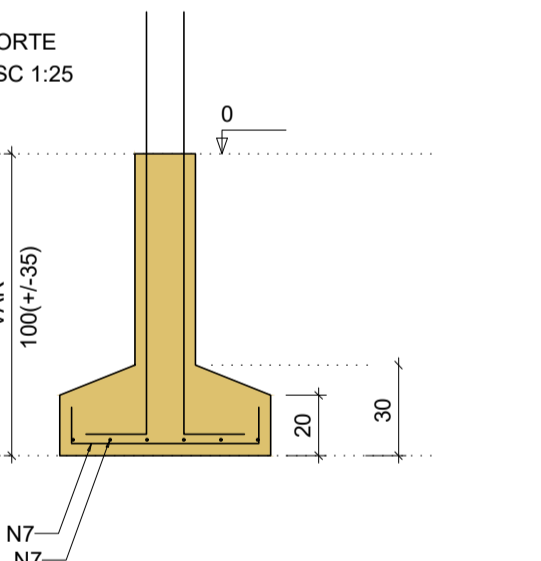
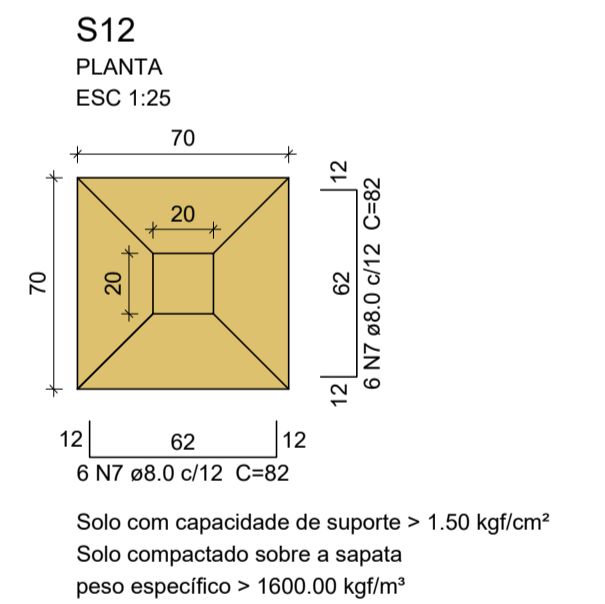
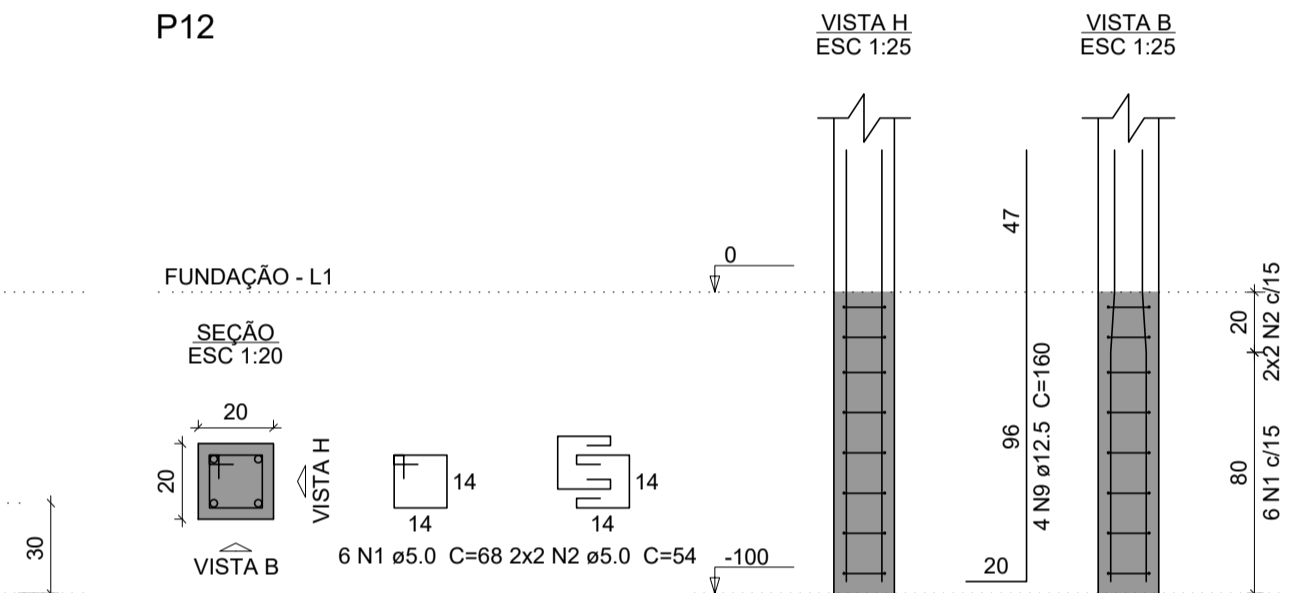
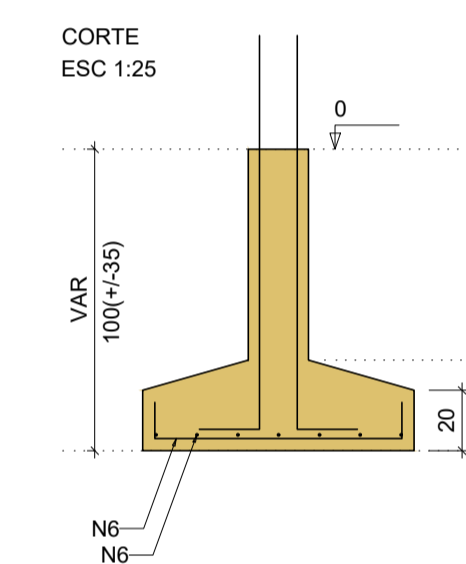
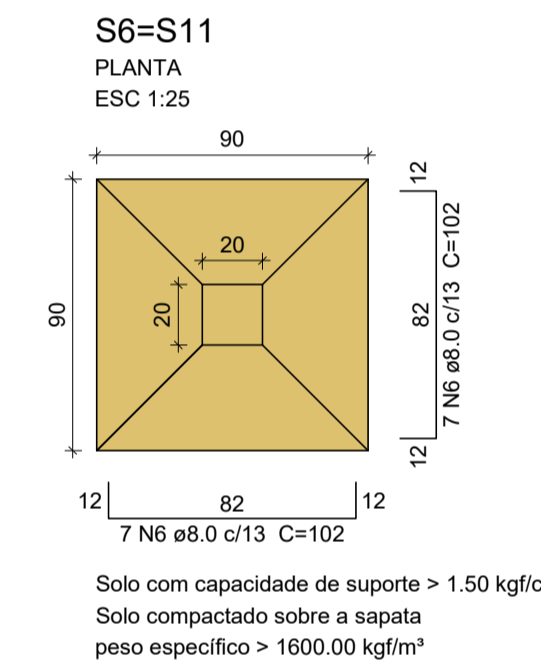
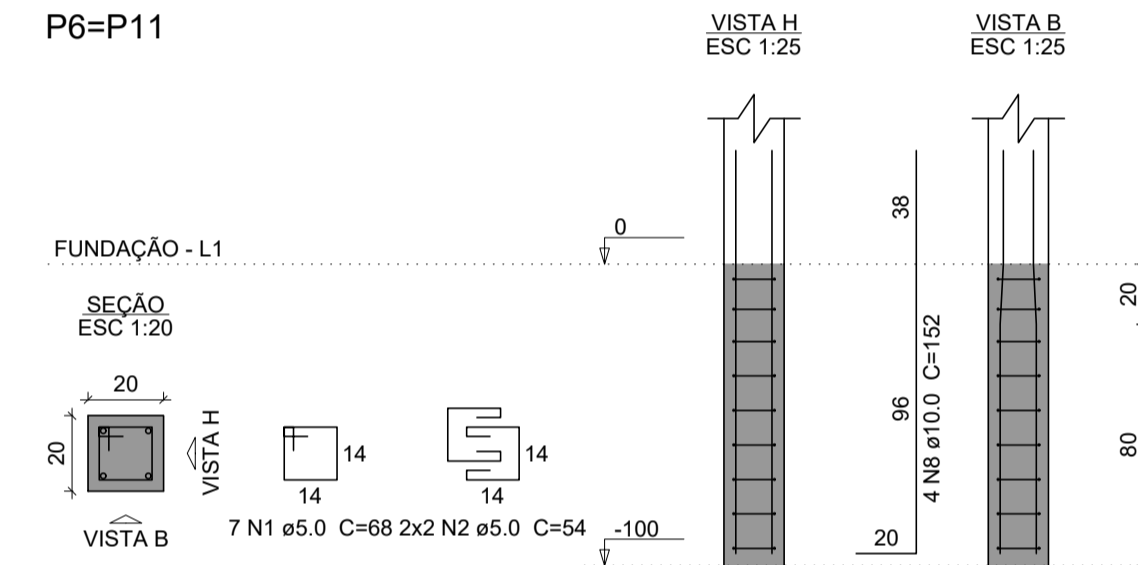
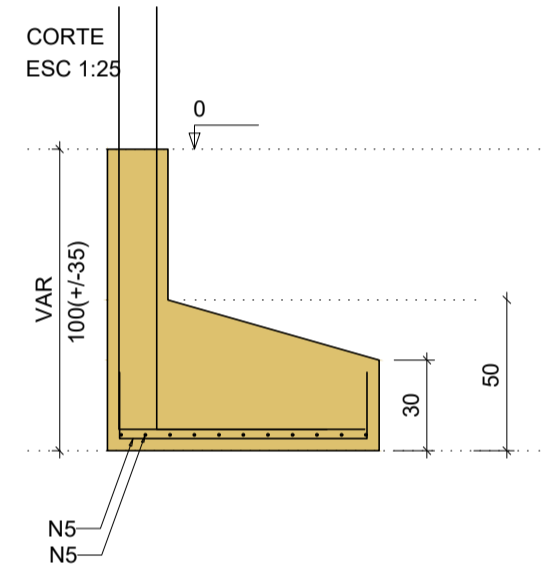
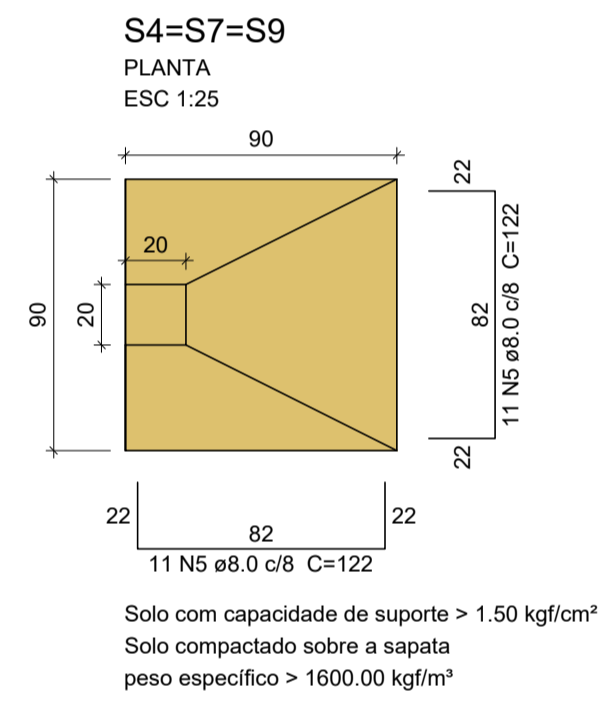
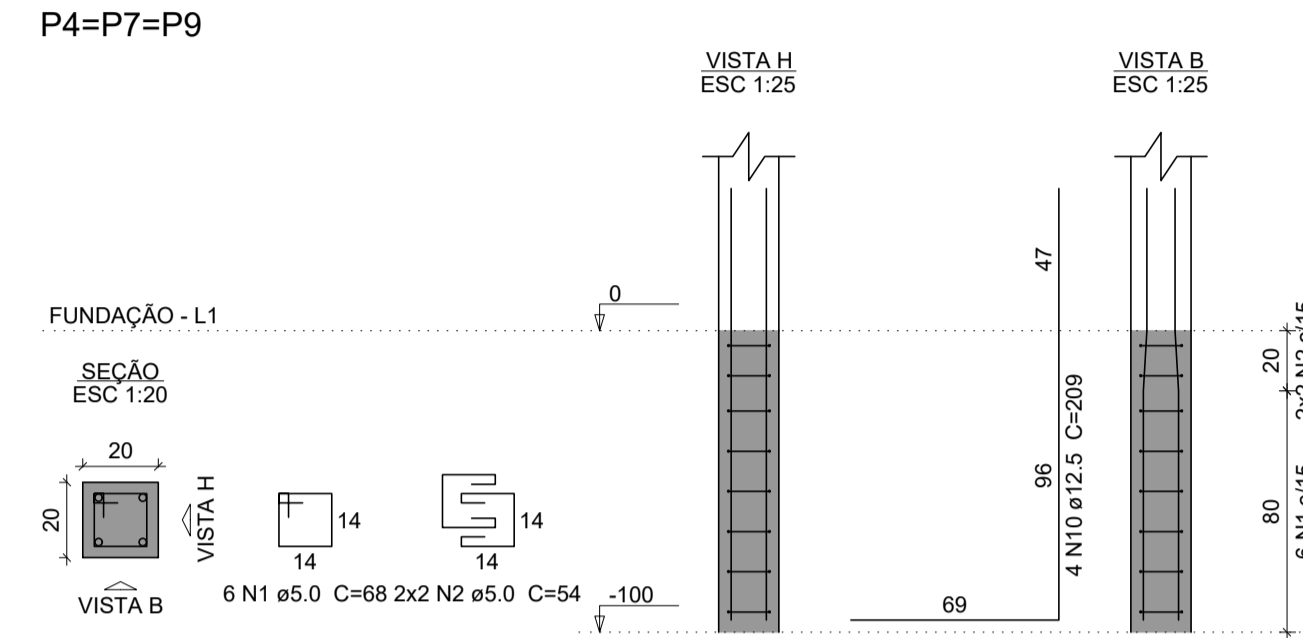
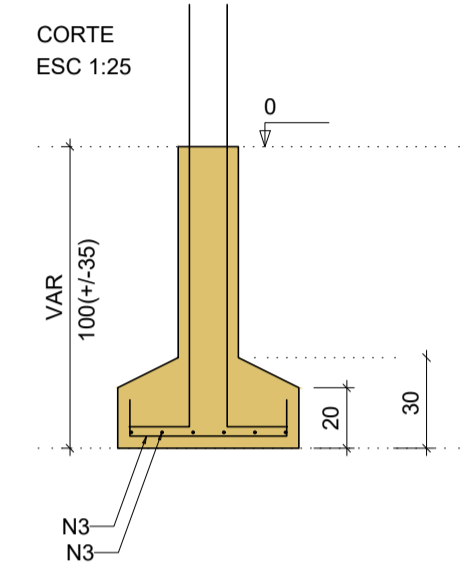
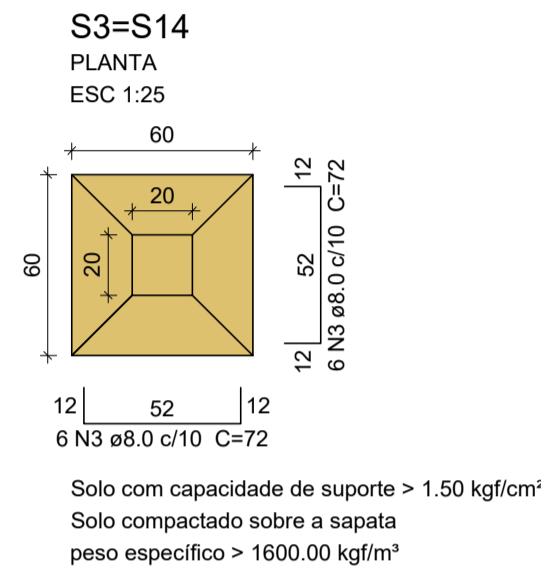
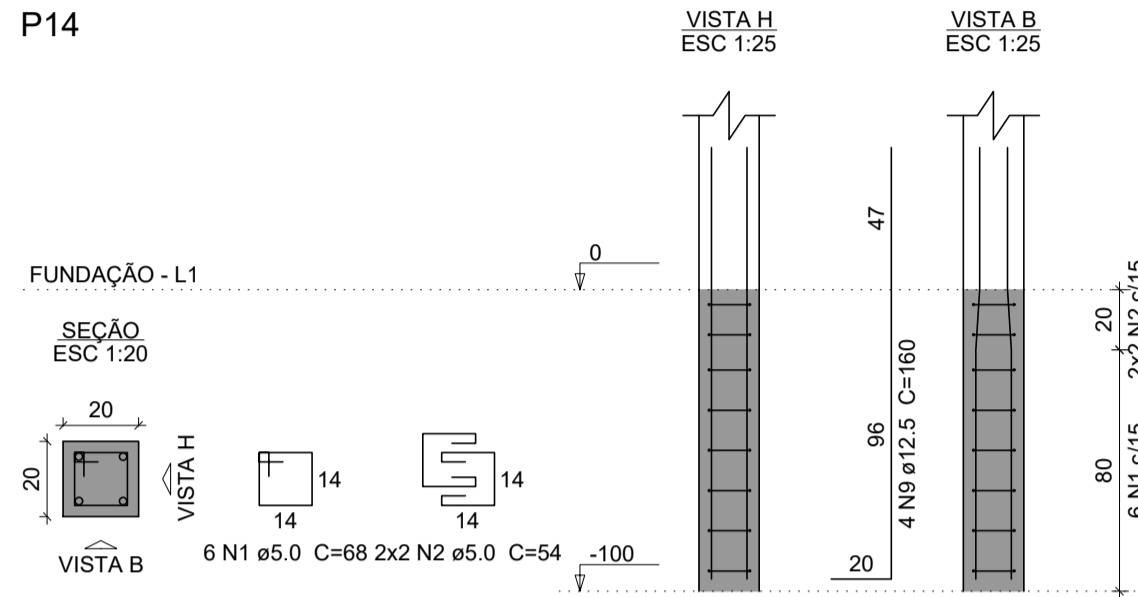
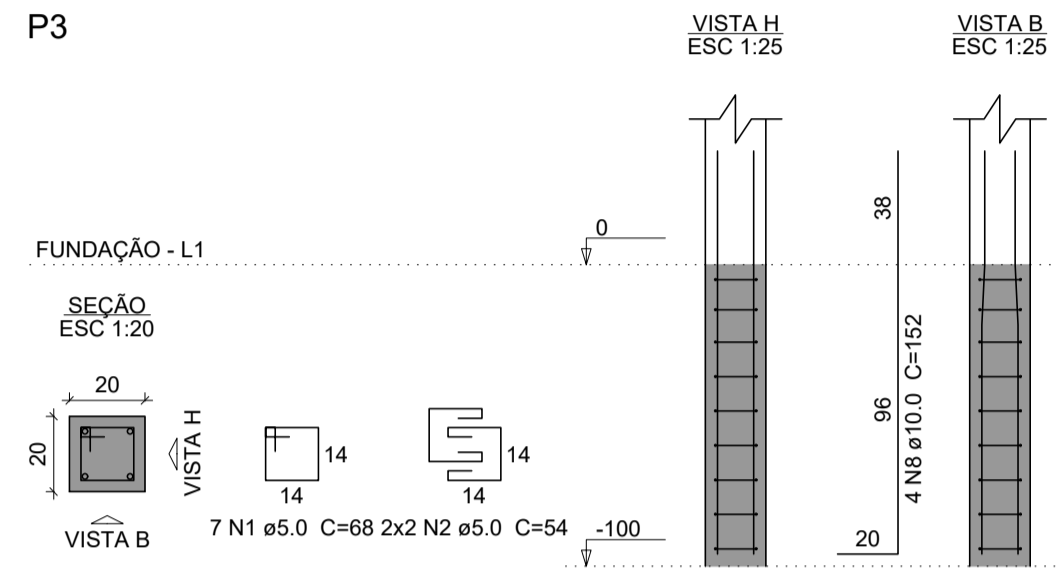

NOTAS

LEGENDA

MAPA-CHAVE

ATUALIZAÇÃO

CONTRATANTE: **PREFEITURA MUNICIPAL DE CLARO DOS POÇOS/MG**
CNPJ Nº: 23.539.463/0001-21
Rua. Coqueiros, 51
Centro, Claro dos Poços/MG,
CEP: 39.350-000

CONTRATADA: **CA**
CARVALHO AMARAL ENGENHARIA
CNPJ Nº: 16.783.066/0001-35
Avenida Mestre Firmino, nº 726,
1º andar, Centro, Montes Claros/MG,
CEP: 39401-074

RESPONSÁVEL TÉCNICO: **MAX HENRIQUE VELOSO DA SILVA** CREA: 248.998/D

MUNICÍPIO/ÁREA: **MUNICÍPIO DE CLARO DOS POÇOS/MG**

ENDEREÇO DA OBRA: **AVENIDA ILDO HORTA S/N**

DATA: **18/01/2023** ESCALA: **INDICADA** PRANCHA: **02/05**

ARQUIVO: **DE-2023.2369-MG.CLA-ARQ-EXE.001=0**